



(19) **United States**

(12) **Patent Application Publication**

(10) **Pub. No.: US 2005/0285151 A1**

Kawasaki

(43) **Pub. Date:**

Dec. 29, 2005

(54) **ACTIVE MATRIX TYPE DISPLAY APPARATUS AND A DRIVING DEVICE OF A LOAD**

(52) **U.S. Cl.** 257/213; 257/88

(75) **Inventor:** Somei Kawasaki, Saitama-shi (JP)

(57) **ABSTRACT**

Correspondence Address:
FITZPATRICK CELLA HARPER & SCINTO
30 ROCKEFELLER PLAZA
NEW YORK, NY 10112 (US)

An active matrix type display device having a plurality of pixel circuits (1) arranged in a matrix shape. The pixel circuit has: a display device (EL); a drive transistor (M1) of a first conductivity type for controlling a current flowing in the display device; a capacitor (C1) provided at a control electrode of the drive transistor; and a switch (M2a, M2b), connected to the control electrode of the drive transistor, for holding a drive control signal at the capacitor. The switch includes a switching transistor (M2a) of the first conductivity type and a switching transistor (M2b) of a second conductivity type in which one main electrode of the switching transistor of the first conductivity type and one main electrode of the switching transistor of the second conductivity type are connected serially. One of the other main electrode of the switching transistor of the first conductivity type and the other main electrode of the switching transistor of the second conductivity type is connected to the control electrode of the drive transistor.

(73) **Assignee:** Canon Kabushiki Kaisha, Tokyo (JP)

(21) **Appl. No.:** 11/152,188

(22) **Filed:** Jun. 15, 2005

(30) **Foreign Application Priority Data**

Jun. 24, 2004 (JP) 2004-186483

Publication Classification

(51) **Int. Cl.⁷** H01L 29/745

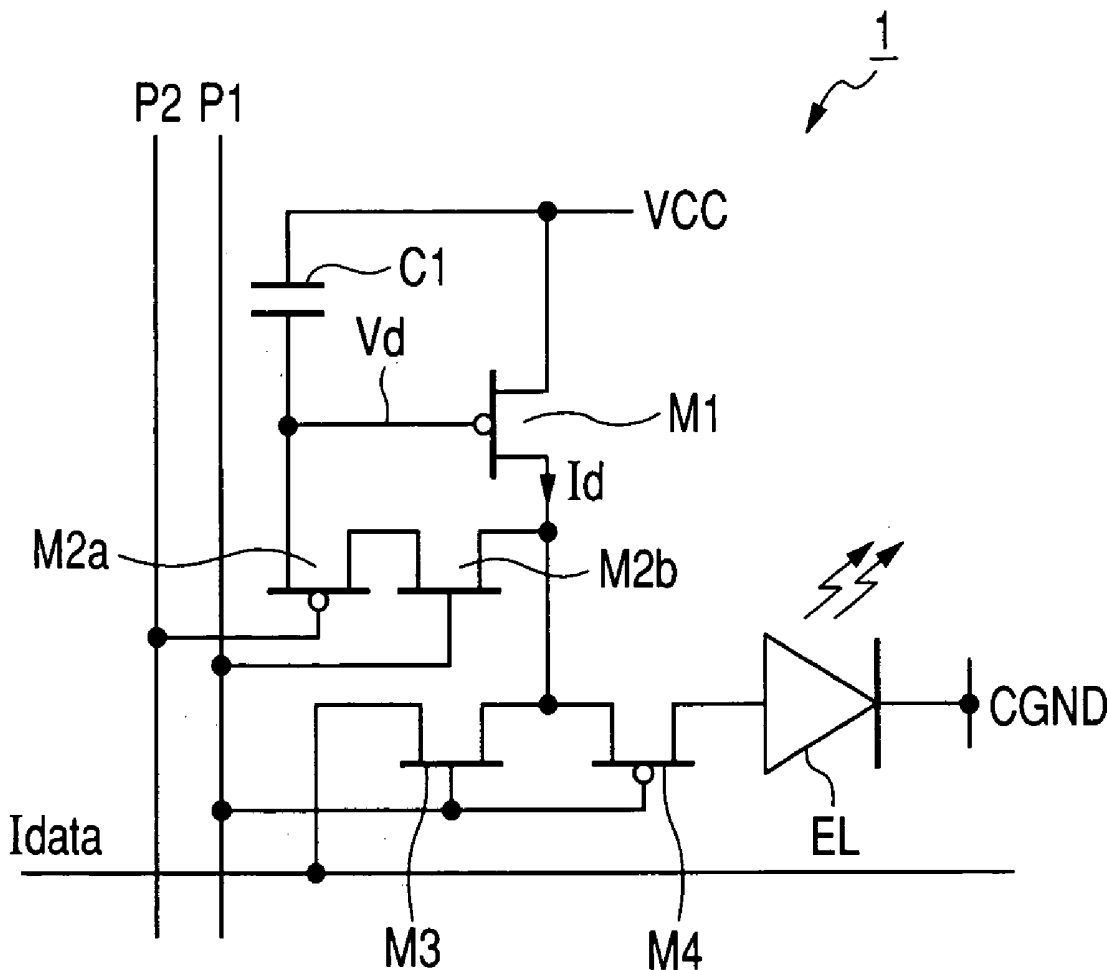

FIG. 1

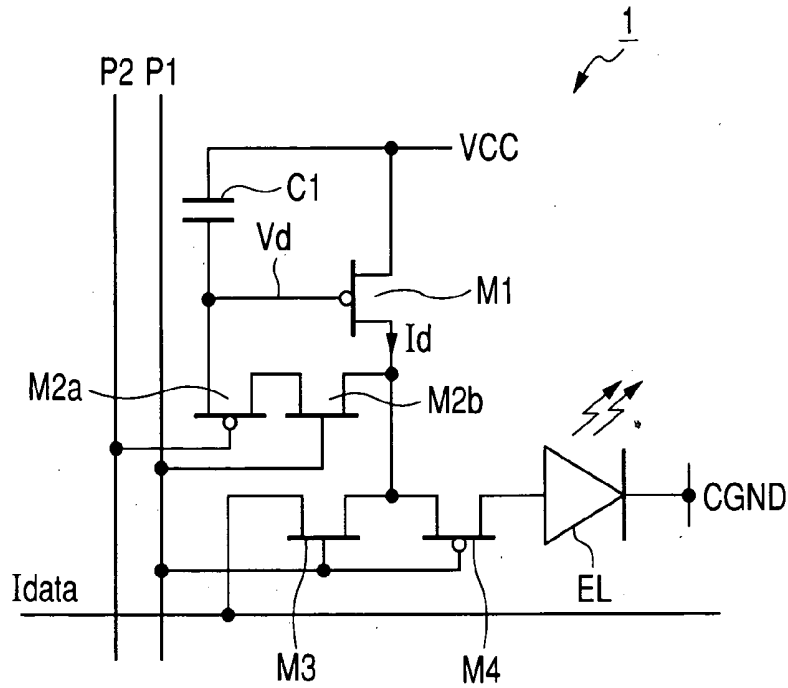

FIG. 2

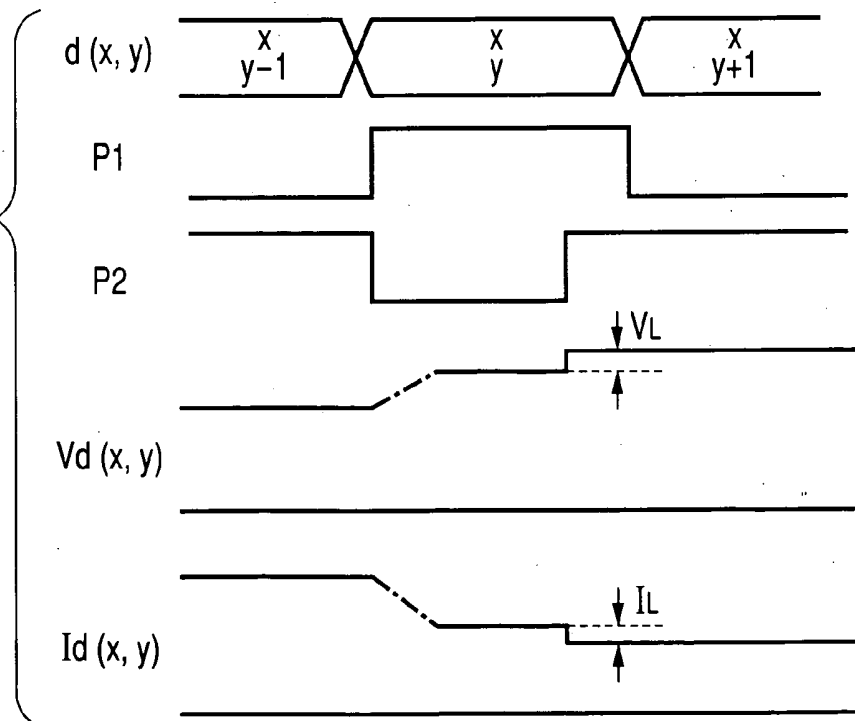

FIG. 3

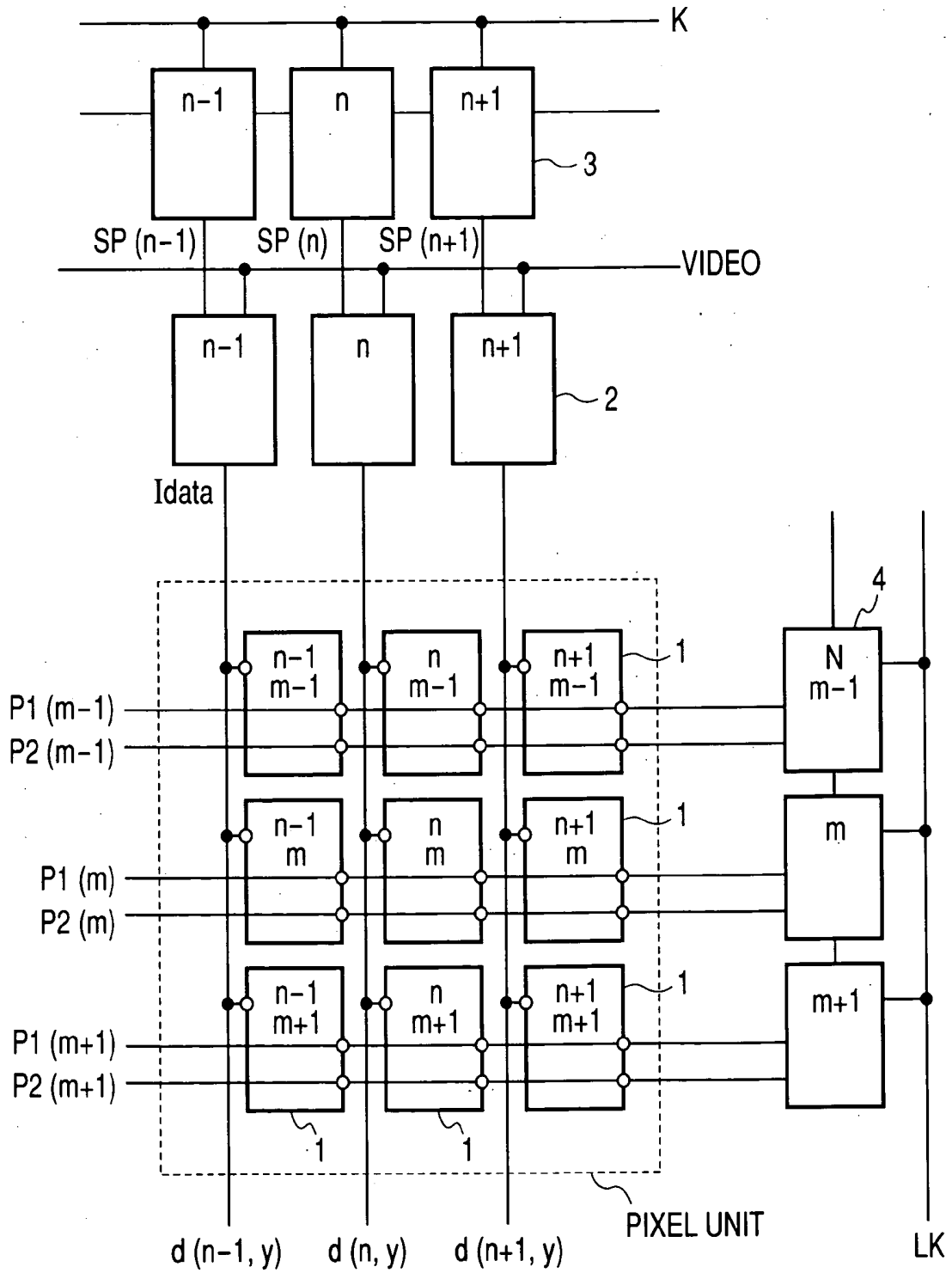

FIG. 4

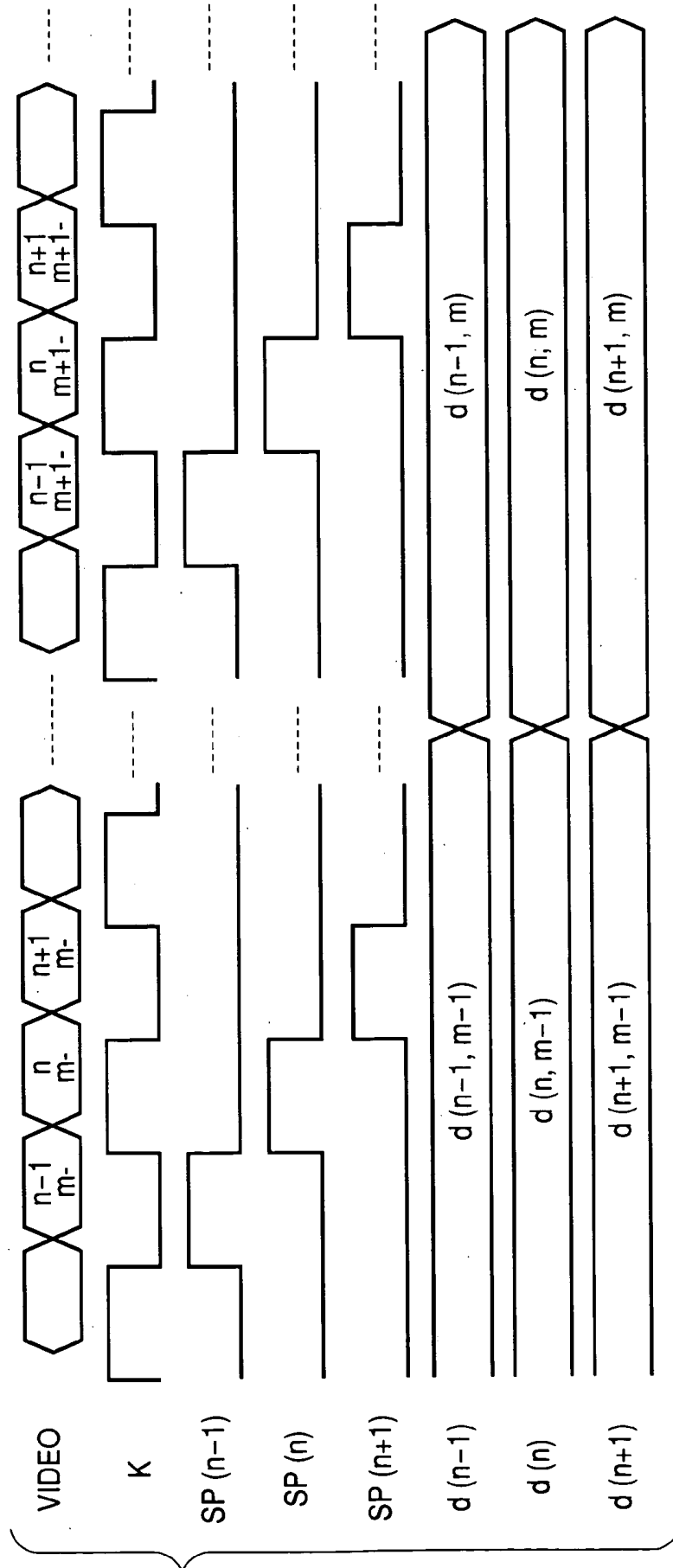

FIG. 5

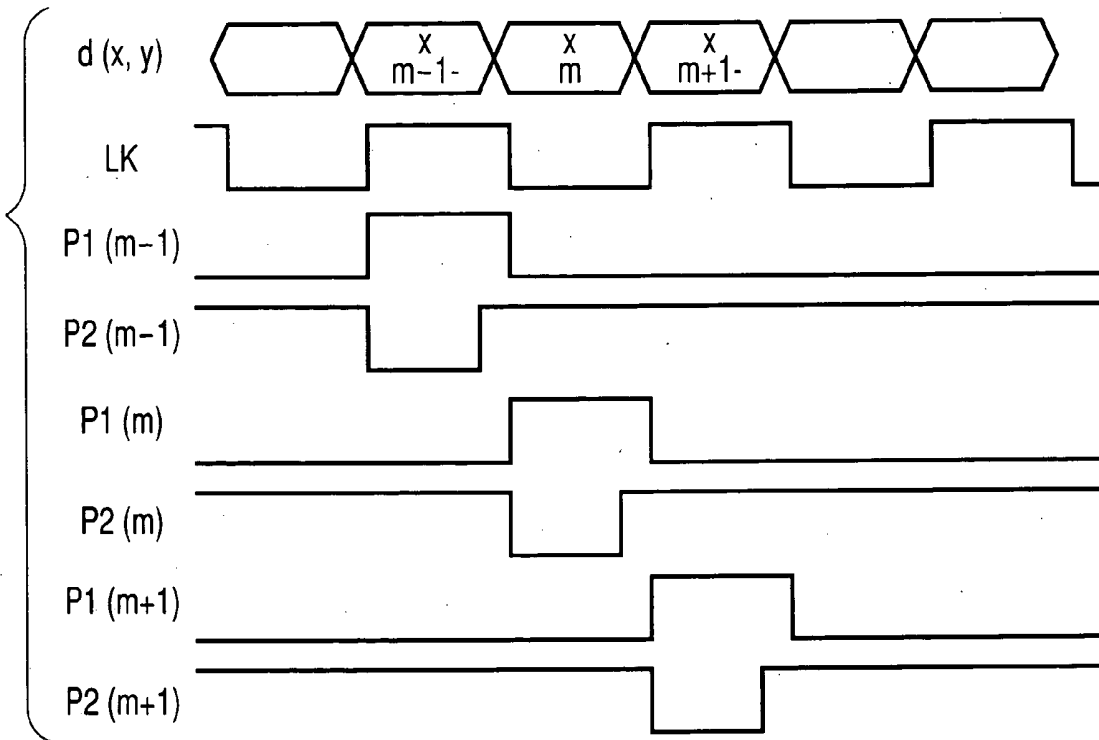
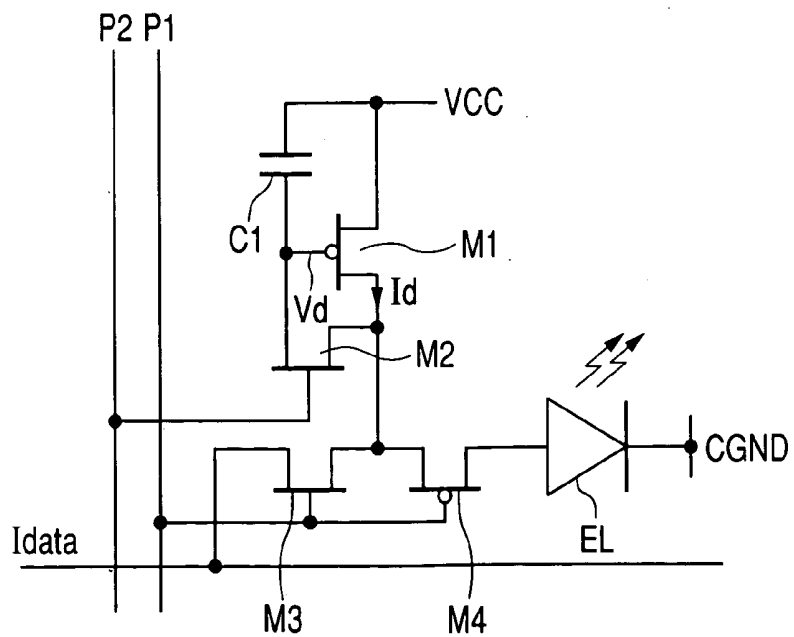

FIG. 6



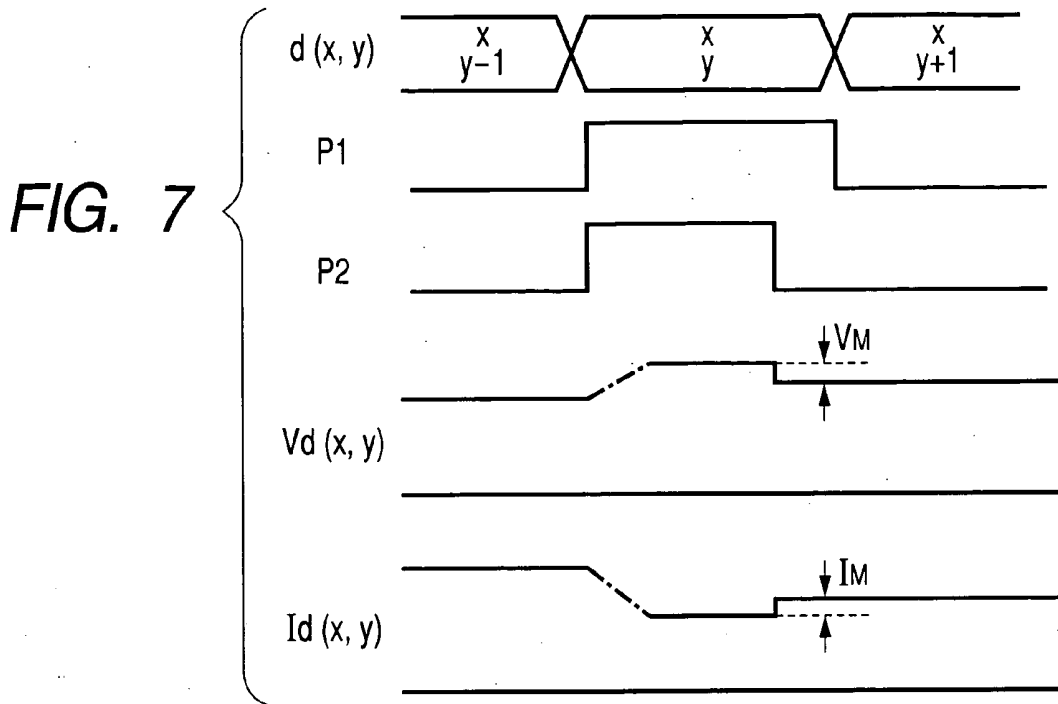

FIG. 8

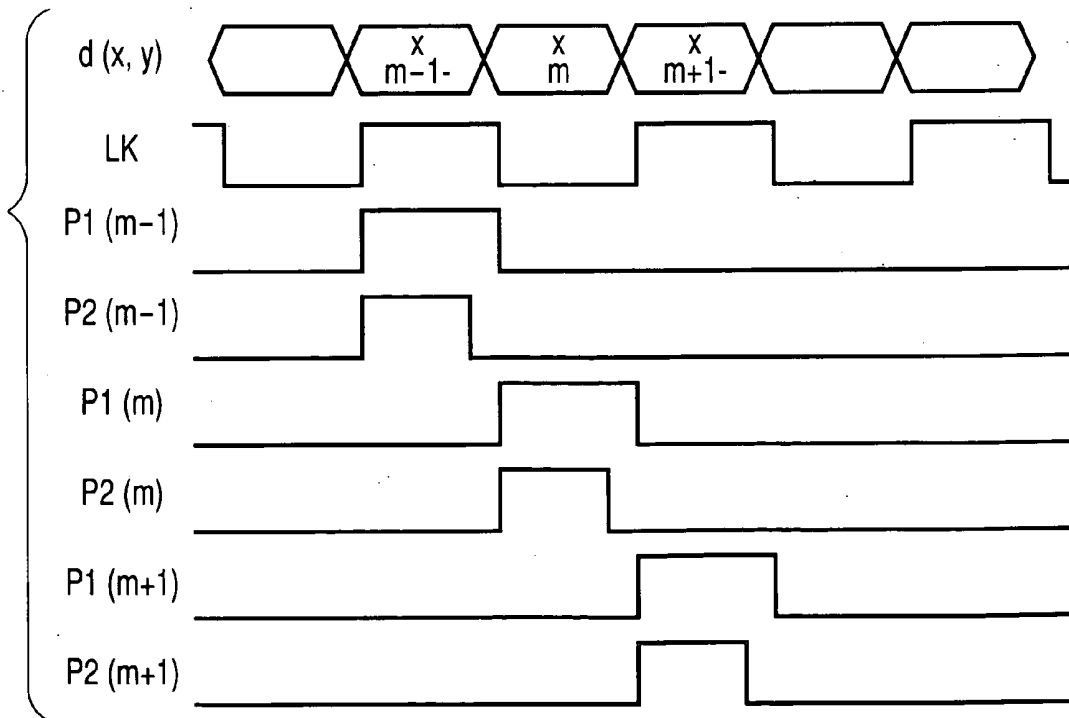

FIG. 9

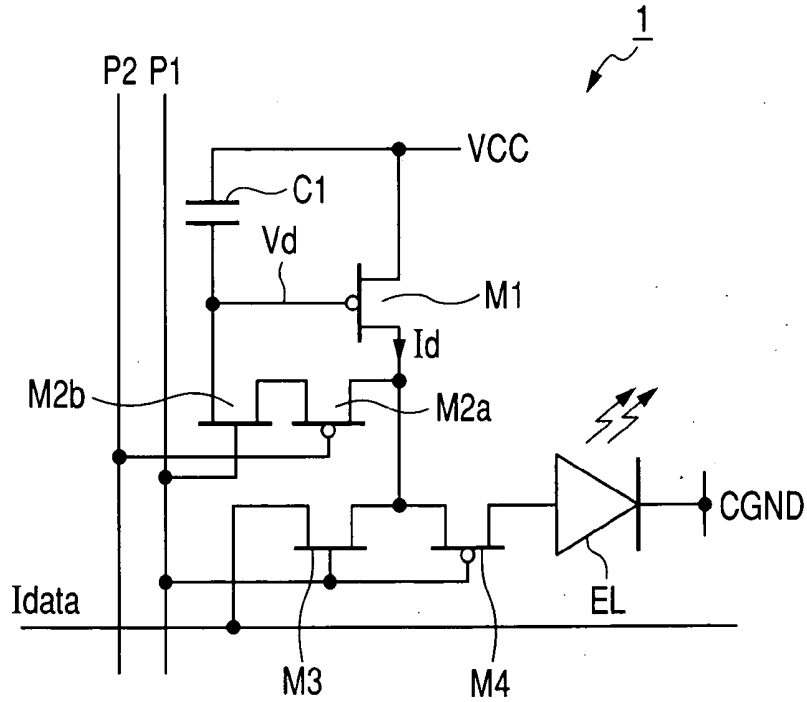

FIG. 10

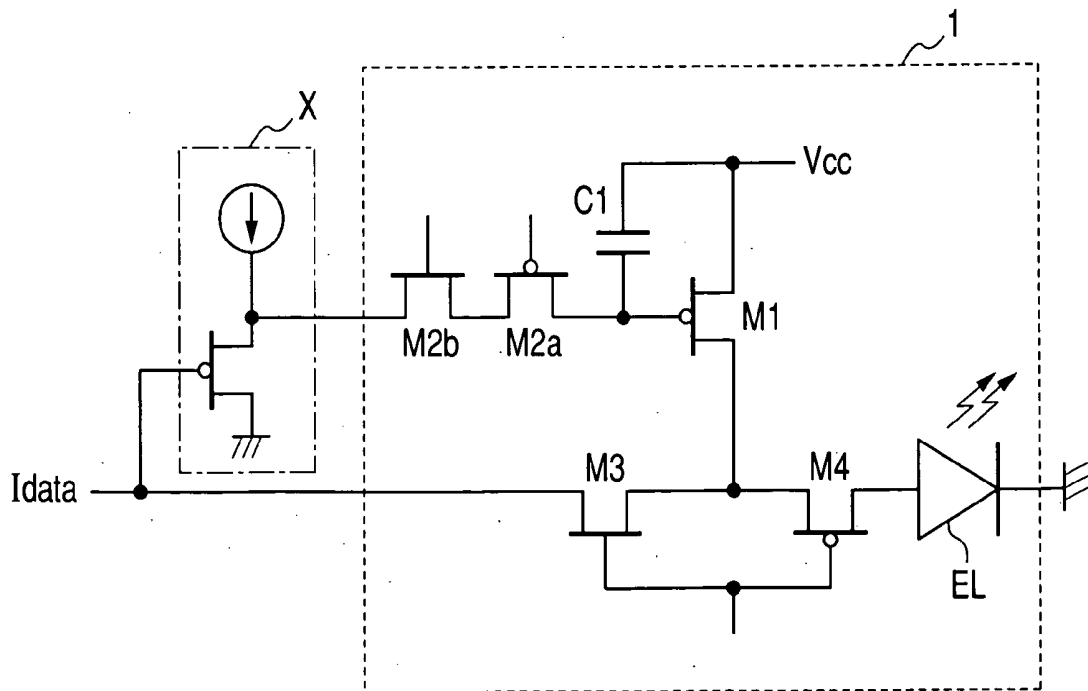

FIG. 11

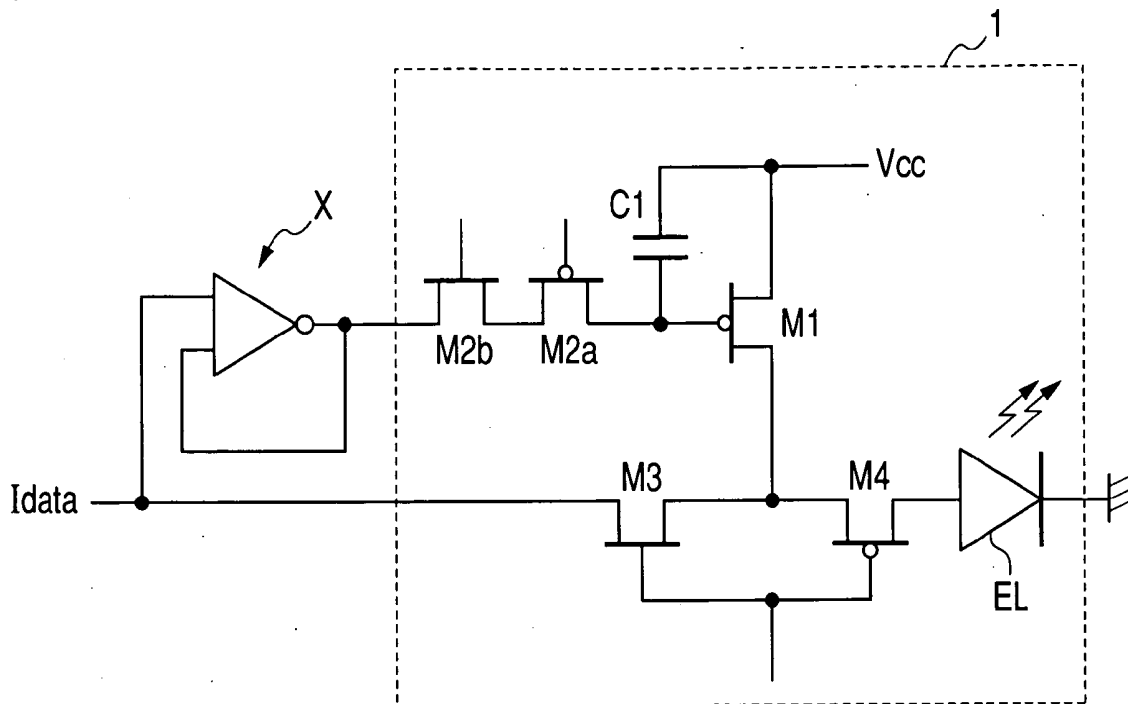

FIG. 12

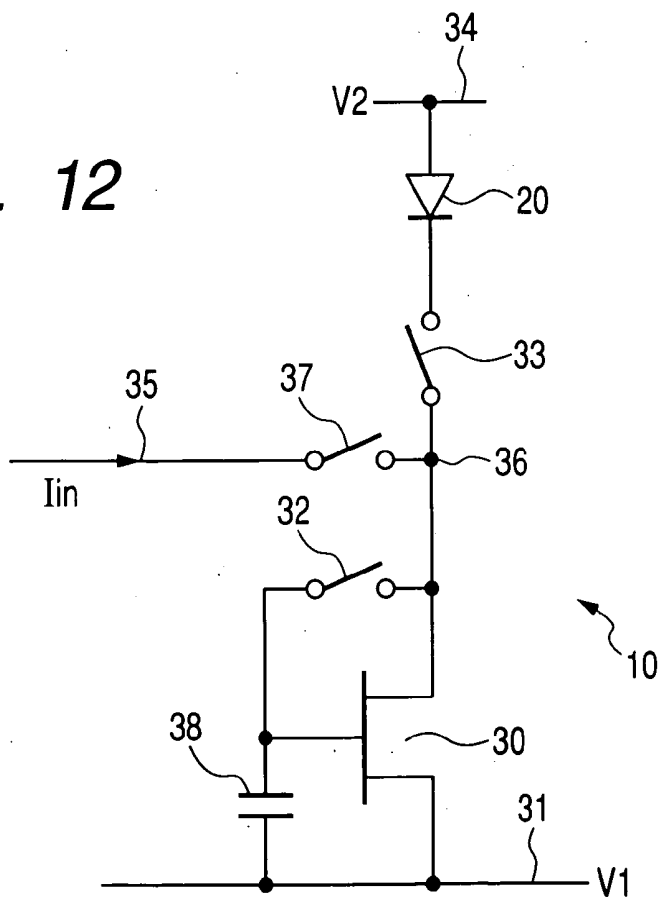

FIG. 13A

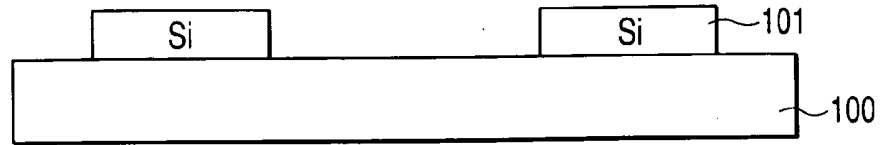

FIG. 13B

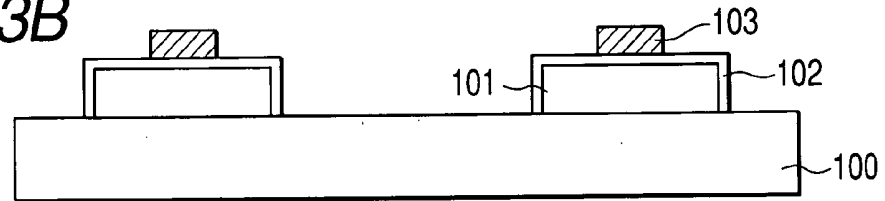

FIG. 13C

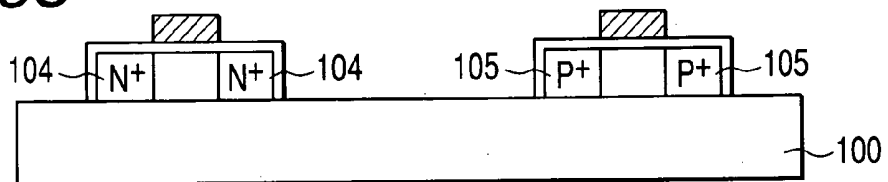

FIG. 13D

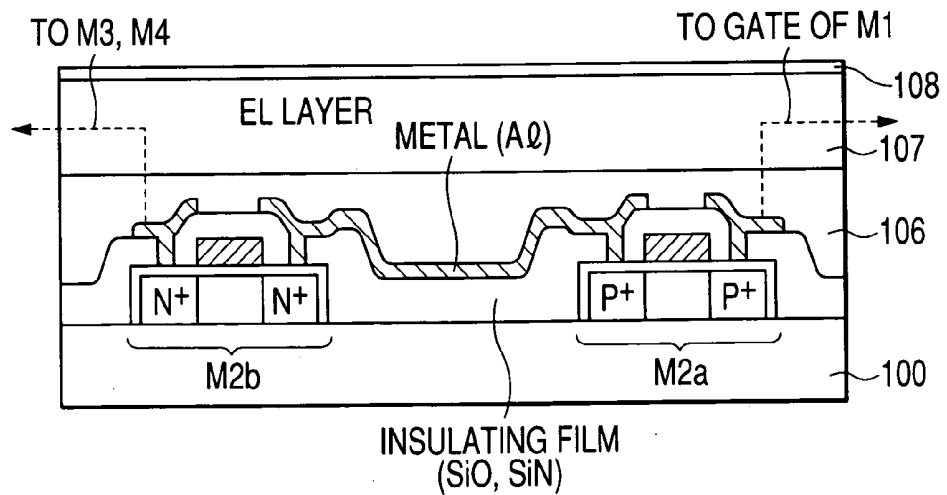
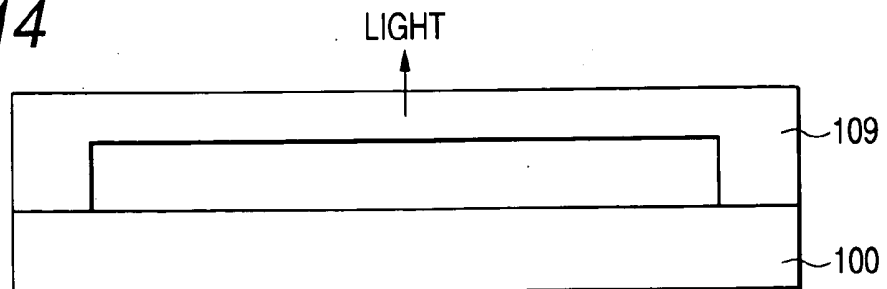

FIG. 14



ACTIVE MATRIX TYPE DISPLAY APPARATUS AND A DRIVING DEVICE OF A LOAD

BACKGROUND OF THE INVENTION

[0001] 1. Field of the Invention

[0002] The invention relates to an active matrix type display apparatus and a driving device of a load which are used for a television receiver, monitors of a computer, a cellular phone, a digital camera, a digital video camera (camcorder), and the like, an exposure device for an electrophotography printer, an exposure light source for a photolithography, and the like. More particularly, the invention relates to an active matrix type display apparatus (or device) and a driving device (or apparatus) of an active device as a load which are preferably used for a current driving type display device.

[0003] 2. Related Background Art

[0004] As an active matrix electroluminescent display device, for example, there is a device disclosed in JP-A-2002-517806. FIG. 12 is a circuit diagram of a conventional pixel circuit.

[0005] The circuit shown in FIG. 12 operates as follows. Switches (transistors) 37 and 32 are closed. A switch (transistor) 33 is opened. An input signal I_{in} corresponding to a device current necessary for light emission of an electroluminescent device 20 as an active device is inputted. A voltage across a capacitor 38 in a stationary state becomes a gate-source voltage necessary to drive a current flowing in a channel of a drive transistor 30. When the switches 37 and 32 are opened, the gate-source voltage which is determined in accordance with the input signal I_{in} is held in the capacitor 38.

[0006] Subsequently, when the switch 33 is closed, a drive current according to a level of the holding voltage flows in the electroluminescent device 20 through the drive transistor 30, so that light is emitted. Reference numeral 34 denotes a power line for setting a voltage (V_2) on the anode side of the electroluminescent device 20 and 31 indicates a power line for setting a voltage (V_1) on the source side of the transistor.

[0007] In JP-A-2002-517806, there is such a disclosure that n-type MOS transistors are used as transistors 32, 37, and 30 and a p-type MOS transistor is used as a transistor 33.

[0008] There is also known a pixel circuit in which a p-type MOS transistor is used as a drive transistor and a p-type MOS transistor is used as a switching transistor for short-circuiting a circuit between a gate and a drain of the drive transistor. (Refer to the Official Gazette of International Publication No. WO01/91094.)

[0009] In the active matrix type display device and the driving apparatus of the active device, there is still a room to be improved from two viewpoints in which the drive current in the dark state is set to zero and a fluctuation of the drive current due to an unnecessary leakage current is prevented.

SUMMARY OF THE INVENTION

[0010] It is an object of the invention to provide an active matrix type display device and a driving apparatus of an

active device, in which a drive current in a dark state is suppressed and an unnecessary leakage current can be suppressed.

[0011] It is another object of the invention to provide an active matrix type display apparatus and a driving device of a load, in which luminance in a dark state due to a fluctuation of a holding voltage accompanied by the switching operation can be reduced and a fluctuation of the luminance due to an unnecessary leakage current can be suppressed.

[0012] According to the first invention of the present invention, there is provided an active matrix type display apparatus having a plurality of pixel circuits arranged in a matrix,

[0013] wherein the pixel circuit comprises:

[0014] a display element;

[0015] a drive transistor of a first conductivity type for controlling a current flowing in the display element;

[0016] a capacitor provided at a control electrode of the drive transistor; and

[0017] a switch, connected to the control electrode of the drive transistor, for holding a drive control signal at the capacitor, and

[0018] the switch includes a switching transistor of the first conductivity type and a switching transistor of a second conductivity type in which one main electrode of the switching transistor of the first conductivity type and one main electrode of the switching transistor of the second conductivity type are connected, and one of the other main electrode of the switching transistor of the first conductivity type and the other main electrode of the switching transistor of the second conductivity type is connected to the control electrode of the drive transistor.

[0019] According to the second invention of the present invention, there is provided a driving device of a load, comprising:

[0020] a drive transistor of a first conductivity type for controlling a current flowing in the load;

[0021] a capacitor provided at a control electrode of the drive transistor; and

[0022] a switch, connected to the control electrode of the drive transistor, for holding a drive control signal at the capacitor, and

[0023] the switch includes a switching transistor of the first conductivity type and a switching transistor of a second conductivity type in which one main electrode of the switching transistor of the first conductivity type and one main electrode of the switching transistor of the second conductivity type are connected, and one of the other main electrode of the switching transistor of the first conductivity type and the other main electrode of the switching transistor of the second conductivity type is connected to the control electrode of the drive transistor.

[0024] According to the third invention of the present invention, there is provided an electro-luminescent display apparatus comprising:

- [0025] a plurality of pixel circuits arranged in a matrix an electro-luminescent display element on said pixel circuit;
- [0026] wherein said pixel circuit comprises:
- [0027] a drive transistor of a first conductivity type for controlling a current flowing in said display element;
- [0028] a capacitor provided at a control electrode of said drive transistor; and
- [0029] a switch, connected to said control electrode of said drive transistor, for holding a drive control signal at said capacitor, and
- [0030] said switch includes a switching transistor of the first conductivity type and a switching transistor of a second conductivity type in which one main electrode of said switching transistor of the first conductivity type and one main electrode of said switching transistor of the second conductivity type are connected, and one of the other main electrode of said switching transistor of the first conductivity type and the other main electrode of said switching transistor of the second conductivity type is connected to said control electrode of said drive transistor.
- [0031] According to the forth invention of the present invention, there is provided a light emitting apparatus comprising:
- [0032] a plurality of pixel circuits arranged in a matrix,
- [0033] a light emitting element being connected with said pixel circuit;
- [0034] wherein said pixel circuit comprises:
- [0035] a drive transistor of a first conductivity type for controlling a current flowing in said display element;
- [0036] a capacitor provided at a control electrode of said drive transistor; and
- [0037] a switch, connected to said control electrode of said drive transistor, for holding a drive control signal at said capacitor, and
- [0038] said switch includes a switching transistor of the first conductivity type and a switching transistor of a second conductivity type in which one main electrode of said switching transistor of the first conductivity type and one main electrode of said switching transistor of the second conductivity type are connected, and one of the other main electrode of said switching transistor of the first conductivity type and the other main electrode of said switching transistor of the second conductivity type is connected to said control electrode of said drive transistor.
- [0039] As will be explained hereinafter with reference to FIG. 1, it is preferable to construct in such a manner that
- [0040] the other one of the other main electrode of a switching transistor M2a of the first conductivity type and the other main electrode of a switching transistor M2b of the second conductivity type is connected to one main electrode (drain) of a drive transistor M1, and
- [0041] by turning on both of the switching transistor of the first conductivity type and the switching transistor of the second conductivity type, the control electrode (gate) and the one main electrode (drain) of the drive transistor are short-circuited.
- [0042] It is also preferable that the other main electrode of the switching transistor of the first conductivity type is connected to the control electrode of the drive transistor.
- [0043] Further, it is also preferable that
- [0044] a switching transistor M3 of the second conductivity type for selecting a row is provided between the one main electrode (drain) of the drive transistor and a signal line (Idata, d(x, y)),
- [0045] a switching transistor M4 of the first conductivity type for selecting light emission is provided on a path of the current flowing in the display device (EL), and
- [0046] a control electrode of the switching transistor M2b of the second conductivity type, a control electrode of the switching transistor M3 for selecting the row, and a control electrode of the switching transistor M4 for selecting the light emission are connected in common to a second scan signal line.
- [0047] As shown in FIG. 2, it is also preferable that after time when the switching transistor of the first conductivity type is changed from ON to OFF (timing when P2 is changed from the low level to the high level), the switching transistor of the second conductivity type is changed from ON to OFF (P2 is changed from the high level to the low level).
- [0048] Or, as will be explained hereinafter with reference to FIG. 9, it is also preferable that the other main electrode of the switching transistor of the second conductivity type is connected to one main electrode of the drive transistor.
- [0049] Also in the case of FIG. 9, it is also preferable that the switching transistor of the second conductivity type for selecting the row is provided between the one main electrode of the drive transistor and the signal line,
- [0050] the switching transistor of the first conductivity type for selecting the light emission is provided on the path of the current flowing in the display device, and
- [0051] the control electrode of the switching transistor of the second conductivity type, the control electrode of the switching transistor for selecting the row, and the control electrode of the switching transistor for selecting the light emission are connected in common to the second scan signal line.
- [0052] As will be explained hereinafter with reference to FIGS. 10 and 11, it is also preferable that the other one of the other main electrode of the switching transistor of the first conductivity type and the other main electrode of the switching transistor of the second conductivity type is connected to an output terminal of a voltage buffer X, and

[0053] an input terminal of the voltage buffer is connected to the signal line (I_{data}, d(x, y)).

[0054] As shown in FIG. 10, it is also preferable that the other one of the other main electrode of the switching transistor of the first conductivity type and the other main electrode of the switching transistor of the second conductivity type is connected to an output terminal of a source follower circuit and an input terminal of the source follower circuit is connected to the signal line.

[0055] As shown in FIG. 11, it is also preferable that the other one of the other main electrode of the switching transistor of the first conductivity type and the other main electrode of the switching transistor of the second conductivity type is connected to an output terminal of a feedback type operational amplifier and an input terminal of the feedback type operational amplifier is connected to the signal line.

[0056] According to the present invention, it is also preferable that the drive transistor of the first conductivity type and the switching transistor of the first conductivity type are p-channel type thin film transistors and the switching transistor of the second conductivity type is an n-channel type thin film transistor.

BRIEF DESCRIPTION OF THE DRAWINGS

[0057] FIG. 1 is a diagram showing an example of a construction of a pixel circuit according to the first embodiment of the invention;

[0058] FIG. 2 is a timing chart for explaining the operation of the pixel circuit according to the first embodiment of the invention;

[0059] FIG. 3 is a diagram showing a construction of an active matrix electroluminescent display device according to the invention;

[0060] FIG. 4 is a timing chart for explaining the generating operation of line sequential data line signals;

[0061] FIG. 5 is a timing chart for explaining the generating operation of row scan signals of the pixel circuit shown in FIG. 1;

[0062] FIG. 6 is a diagram showing a construction of a pixel circuit of a comparison example regarding the first embodiment of the invention;

[0063] FIG. 7 is a timing chart for explaining the operation of the pixel circuit in FIG. 6;

[0064] FIG. 8 is a timing chart for explaining the generating operation of row scan signals of the pixel circuit shown in FIG. 6;

[0065] FIG. 9 is a diagram showing an example of a construction of a pixel circuit according to the second embodiment of the invention;

[0066] FIG. 10 is a diagram showing an example of a construction of a pixel circuit and a voltage buffer circuit according to the third embodiment of the invention;

[0067] FIG. 11 is a diagram showing a modification of the pixel circuit and the voltage buffer circuit according to the third embodiment of the invention;

[0068] FIG. 12 is a circuit diagram of a conventional pixel circuit;

[0069] FIGS. 13A, 13B, 13C and 13D are diagrams showing manufacturing steps of the portions of a pMOS transistor M2a and an nMOS transistor M2b which are used in the invention; and

[0070] FIG. 14 is a cross sectional view showing a construction of an EL display device manufactured by the manufacturing method of FIG. 13.

DETAILED DESCRIPTION OF THE PREFERRED EMBODIMENTS

[0071] In a pixel circuit shown in FIG. 6, the inventors et al. of the present invention manufactured the pixel circuit by using: a p-type MOS transistor using low-temperature polysilicon as a drive transistor; and an n-type MOS transistor using low-temperature polysilicon as a switching transistor for short-circuiting a circuit between a gate and a drain of the drive transistor. In this case, in a black display mode, sufficient darkness is not accomplished due to a drop of a voltage held between the gate and a source accompanied by the switching operation. This results in reduction of contrast in the case of using the pixel circuit for a display device, an exposure device, or an exposure light source.

[0072] A pixel circuit is also manufactured by using: a p-type MOS transistor using low-temperature polysilicon as a drive transistor; and a p-type MOS transistor using low-temperature polysilicon as a switching transistor for short-circuiting a circuit between the gate and the drain of the drive transistor. In this case, although the sufficient darkness is obtained in the black display mode, it has been found that a leakage current through the switching transistor occurs. Preferred embodiments to solve such problems will be described in detail hereinbelow with reference to the drawings.

[0073] According to the preferred embodiments of the invention, the reduction of the contrast due to the fluctuation in holding voltage accompanied by the switching operation can be suppressed and the generation of the leakage current can be suppressed.

First Embodiment

[0074] FIG. 1 is a diagram showing an example of a construction of a pixel circuit according to the first embodiment of the invention. FIG. 2 is a timing chart for explaining the operation of the pixel circuit of FIG. 1.

[0075] FIG. 3 is a constructional diagram showing a construction of an active matrix electroluminescent display device according to the invention.

[0076] In FIG. 3, reference numeral 1 denotes pixel circuits arranged in a matrix shape; 2 voltage-current converting circuits as signal line drive circuits which are connected to the pixel circuits 1 arranged in the column direction and supply line sequential data line current signals I_{data} to the pixel circuits 1 through signal lines d(x, y); 3 column shift registers connected to the voltage-current converting circuits 2; and 4 row shift registers serving as scan line drive circuits which are connected to the pixel circuits 1 arranged in the row direction and output a row scan signal P1 and a

row scan signal P2 to the pixel circuits 1. A plurality of pixel circuits 1 are arranged in a matrix shape and construct a pixel unit.

[0077] FIG. 4 is a timing chart for explaining the generating operation of the line sequential data line signals. A clock signal K is inputted to the column shift registers 3. A video signal (Video) is inputted to the voltage-current converting circuits 2. The voltage-current converting circuits 2 supply the line sequential data line current signals Idata (d(n-1) to d(n+1)) to the columns of the pixel circuits on the basis of signals SP(n-1) to SP(n+1) from the column shift registers 3.

[0078] FIG. 5 is a timing chart for explaining the generating operation of row scan signals of the pixel circuit shown in FIG. 1, which will be explained hereinafter. A clock signal LK is inputted to the row shift registers 4. The row scan signals P1 (P1(m-1) to P1(m+1)) and the row scan signals P2 (P2(m-1) to P2(m+1)) are sequentially outputted from the row shift registers 4 to the rows of the pixel circuits 1.

[0079] FIG. 6 is a diagram showing a construction of a pixel circuit of a comparison example regarding the embodiment of the invention. FIG. 7 is a timing chart for explaining the operation of the pixel circuit in FIG. 6. FIG. 8 is a timing chart for explaining the generating operation of row scan signals of the pixel circuit shown in FIG. 6.

[0080] A fundamental construction regarding the programming operation of the current signals Idata in the comparison example of FIG. 6 is substantially the same as that of the pixel circuit shown in FIG. 12. In FIG. 12, the switch 32 can be regarded as an nMOS transistor M2, the switch 37 can be regarded as an nMOS transistor M3, and the switch 33 can be regarded as a pMOS transistor M1.

[0081] First, prior to explaining the embodiment, the comparison example will be described for enabling the construction of the invention to be easily understood.

[0082] The operation of the pixel circuit shown in FIG. 6 of x-column and y-row in the case of displaying the pixel in a position of x-column and y-row in the black display mode will now be considered. In FIG. 7, when the row scan signal P1 is set to the high level, the nMOS transistor M3 serving as a switch for a first program (for selecting the row) is turned on and the pMOS transistor M4 serving as a switch for selecting the light emission is turned off. When the row scan signal P2 is set to the high level, the nMOS transistor M2 serving as a switch for a second program is turned on. A voltage of a capacitor C1 connected to a gate of the pMOS transistor M1 serving as a drive transistor is set to a gate-source voltage enough to allow a current for driving an electroluminescent device EL as an active device to flow through the pMOS transistor M1. Subsequently, when the row scan signal P2 is set to the low level, the nMOS transistor M2 serving as a switch for the second program is turned off and the voltage of the capacitor C1 is held. A period of time so far is called a programming period.

[0083] After that, when the row scan signal P1 is set to the low level, the nMOS transistor M3 serving as a switch for the first program (for selecting the row) is turned off and the PMOS transistor M4 serving as a switch for selecting the light emission is turned on. The supply of the drive current to the electroluminescent device EL is controlled by a gate

potential of the drive transistor M1 and the current flowing in the electroluminescent device EL is controlled. A period of time during which the electroluminescent device EL is emitting the light (non-light emission in the case of the black display data) is called a light emitting period.

[0084] In the pixel circuit of FIG. 6, to stably hold the voltage of the capacitor C1, an nMOS transistor whose leakage current is small is used as a transistor serving as a switch for the second program. This is because when the leakage current is large, the drive current in the light emitting period fluctuates.

[0085] However, as shown in FIG. 7, when a gate of the nMOS transistor M2 is switched from the high level to the low level in the programming period, the electric potential of the capacitor C1 is oscillated due to a parasitic capacitance between the gate and drain of the nMOS transistor M2, a voltage Vd(x, y) to be held drops by an amount of V_M, so that the current flowing in the drive transistor M1 is increased by an amount of I_M. In such a case, even in the case where the pixel of x-column and y-row is in the black display mode in the light emitting period, a small current flows in the pMOS transistor M4 due to the drop of the gate potential (holding voltage). Consequently, a small light emission is observed in spite of the black display mode. In other words, the darkest state cannot be normally obtained and it is difficult to assure the contrast.

[0086] In the embodiment, as shown in FIG. 1, the switch for the second program connected between the capacitor C1 (gate of the drive transistor M1) and the drain of the drive transistor M1 is constructed by a pMOS transistor M2a and an nMOS transistor M2b which are serially connected. That is, the construction of the pixel circuit of FIG. 1 differs from that of the comparison example of FIG. 6 with respect to a point that the nMOS transistor M2 in FIG. 6 is replaced by two switching transistors of the different conductivity types which are serially connected (pMOS transistor M2a and nMOS transistor M2b).

[0087] In the case of holding the voltage into the capacitor C1, since a gate of the pMOS transistor M2a is changed from the low level to the high level in the programming period, on the contrary to the potential change shown in FIG. 7, the electric potential of the capacitor C1 is oscillated due to the parasitic capacitance between the gate and drain and the voltage Vd(x, y) to be held is increased by an amount of V_L, so that the current flowing in the drive transistor M1 is decreased by an amount of I_L. Thus, the pixel current flowing in the black display mode can be eliminated or reduced.

[0088] As for the line sequential data line current signals, although the zero current is preferable in the black display mode, it is actually difficult to realize the zero current in terms of the circuit construction. If the current of the line sequential data line current signals is not equal to zero, a pixel current Id cannot be set to zero. In the construction of FIG. 6, when the nMOS transistor M2 is turned off, the voltage held in the capacitor C1 is oscillated and drops. Therefore, the pixel current Id rises further and it becomes further difficult to set the pixel current Id to zero.

[0089] If one of the switches for the second program is constructed by the pMOS transistor like an embodiment, since the direction of the electric potential in the capacitor

C1 to be oscillated is reversed, even if the current of the line sequential data line current signals is not equal to zero, the pixel current I_d in the black display mode can be set to zero or sufficiently reduced due to the increase in electric potential of the capacitor C1.

[0090] Although the leakage current of the pMOS transistor used in the embodiment is larger than that of the nMOS transistor, by adding the nMOS transistor M2b in series with the pMOS transistor like an embodiment, the leakage current is suppressed and the holding voltage V_d in the light emitting period can be stabilized.

[0091] Although the capacitor C1 can be individually formed as a capacitance device, it is not always necessary to be formed as a device but a parasitic capacitor formed between the gate and the drain (overlapped capacitor of a gate electrode and a drain electrode, or the like) can be also used.

[0092] FIGS. 13A to 13D are diagrams showing manufacturing steps of the portions of the pMOS transistor M2a and the nMOS transistor M2b serving as field effect type thin film transistors using low temperature polysilicon. FIG. 14 is a cross sectional view showing a construction of an EL display device manufactured by the manufacturing method of FIGS. 13A to 13D.

[0093] As shown in FIG. 13A, after an amorphous silicon layer is deposited onto a glass substrate 100 by using a plasma CVD method, it is thermally treated (laser annealing) by a laser beam or the like to thereby form a polysilicon layer. By patterning it, polysilicon layers for the pMOS transistor M2a and the nMOS transistor M2b is formed.

[0094] In this step, it is also possible to execute channel doping of dopant (phosphorus or boron) for exhibiting the conductivity type opposite to that of the source-drain to at least one of the polysilicon layers as necessary and adjust a threshold value.

[0095] Subsequently, as shown in FIG. 13B, a gate insulating film 102 of SiO_2 , SiN, or the like is formed, polysilicon is formed and patterned, and a gate electrode 103 is formed.

[0096] As shown in FIG. 13C, p-type impurities (phosphorus or the like) and n-type impurities (boron or the like) are ion-implanted and thermally diffused and source-drain regions 105 of the pMOS transistor M2a and source-drain regions 104 of the nMOS transistor M2b are formed.

[0097] As shown in FIG. 13D, after the insulating film of SiO_2 , SiN, or the like is formed, contact-holes are formed and a metal layer serving as source and drain electrodes and wirings is laminated and patterned. After that, a planarized film 106 is formed, through-holes are formed, an anode electrode (not shown) is formed and patterned, subsequently, an electroluminescent layer (EL layer) 107 is formed by evaporation deposition, ink-jet (liquid-jet) deposition or the like, and an ITO film 108 is formed. Whereby, electroluminescent light emitting elements disposed on pixel circuits and being electrically connected thereto. Preferably, the EL layer comprises a plurality of layers constructing what is called an organic LED. Further, it is preferable that the EL layer is separated and independent every pixel.

[0098] As shown in FIG. 14, the substrate 100 is sealed to a glass vessel 109 by glass, thereby completing the EL display device.

[0099] According to the embodiment described above, the transistor in which the leakage current of the pMOS transistor is extremely larger than that of the nMOS transistor is manufactured. However, there is also a case where the transistor in which the leakage current of the nMOS transistor is larger than that of the pMOS transistor is manufactured in dependence on the manufacturing processes. The invention is also suitably applied to such a case.

Second Embodiment

[0100] FIG. 9 is a diagram showing an example of a construction of a pixel circuit according to the second embodiment of the invention. The signals for making the pixel circuit operative are substantially the same as those shown in FIG. 2. In the first embodiment, as shown in FIG. 1, the pMOS transistor M2a is connected to the gate of the pMOS transistor M1 and the nMOS transistor M2b is connected to the drain of the pMOS transistor M1. However, in the second embodiment, as shown in FIG. 9, the nMOS transistor M2b is connected to the gate of the pMOS transistor M1 and the pMOS transistor M2a is connected to the drain of the pMOS transistor M1.

[0101] Other constructions are similar to those in the first embodiment.

[0102] According to the pixel circuit with such a connecting form as well, the operation and effects similar to those in the first embodiment can be obtained by a feedthrough of the nMOS transistor M2b in the ON state.

Third Embodiment

[0103] To make the pixel circuit shown in FIG. 1 or 9 operative, it is required that the capacitor C1 and the parasitic capacitor due to the intersection or the like of the wirings are charged by the line sequential data line current signals. Although it is required to control the pixel circuit 1 by a small current in order to obtain a high contrast ratio, there is a case where the charging time of the capacitor C1 and the parasitic capacitor becomes long due to the small current and the small current setting operation for one horizontal scan period is insufficient. Such a drawback becomes a further remarkable problem in a TFT circuit in which a threshold voltage variation ΔV_{th} of the current drive transistor M1 of the pixel circuit 1 of each row is large. Since the capacitor C1 has to hold the current driving operation for one frame period of a video signal Video, its capacitance value cannot be set to a small value.

[0104] The embodiment intends to provide a construction in which even if the current signal that is inputted to the pixel circuit is a small current, the setting operation time can be shortened. The construction in which the voltage buffer is added to the pixel circuit as in the embodiment has been disclosed in, for example, JP-A-2004-118181. A source-follower circuit or a feedback type operational amplifier can be used as a voltage buffer.

[0105] FIG. 10 is a diagram showing an example of a construction of a pixel circuit and a voltage buffer circuit according to the third embodiment of the invention.

[0106] In the embodiment, a voltage buffer X whose output voltage is determined by an input voltage is provided every pixel circuit column. The voltage buffer X is constructed by a source-follower circuit. The source-follower circuit comprises a pMOS transistor and a current source. An output terminal side of the voltage buffer X (connecting point of the pMOS transistor and the current source) is

connected to the nMOS transistor **M2b** and an input terminal side (gate of the pMOS transistor) is connected to the input signal line of the line sequential data line current signals **I_{data}**.

[0107] Other constructions are similar to those of the first embodiment.

[0108] As shown in **FIG. 11**, a feedback type operational amplifier can be also used as a voltage buffer in place of the source-follower circuit.

[0109] Also in this case, constructions other than the portions shown in **FIG. 11** are similar to those of the first embodiment.

[0110] According to the embodiment, since the voltage of the same electric potential as that of the drain of the drive transistor **M1** is held in the capacitor **C1** by the operation of the voltage buffer, the current corresponding to the current signal **I_{data}** which is programmed in the pixel circuit can be allowed to flow in the active device **EL**.

[0111] In this manner, the driving in which the adverse influence by a variation in characteristics of every pixel of the drive transistor is suppressed can be executed in a manner similar to those of the first and second embodiments.

[0112] Although the example in which the pMOS transistor is used as a drive transistor **M1** has been mentioned in each of the foregoing embodiments, in the case of using the nMOS transistor as a drive transistor **M1**, it is sufficient to reverse the polarities of the active device, signals, and power source. Specifically speaking, it is preferable that a drain of the nMOS transistor for driving is connected to a cathode side of an LED as an active device, an anode of the LED is connected to a high potential power source, and a source of the nMOS transistor for driving is connected to a low potential power source.

[0113] Various emitting devices such as inorganic LED, organic LED (organic EL), electron emitting device, semiconductor laser, and the like can be used as active devices (loads) which are used in the invention.

[0114] Further, although the invention is suitably used for the crystalline thin film transistor represented by what is called a low temperature poly-crystalline silicon, the circuit construction of the invention can be constructed by an amorphous silicon TFT, a mono-crystalline silicon TFT, a high temperature poly-crystalline silicon TFT, or the like.

[0115] Particularly, the invention is suitably applied to use for an active matrix type display device of a current driving type light emitting device such as an electroluminescent device (EL device) or the like.

[0116] This application claims priority from Japanese Patent Application No. 2004-186483 filed on Jun. 24, 2004, which is hereby incorporated by reference herein.

What is claimed is:

1. An active matrix type display apparatus having a plurality of pixel circuits arranged in a matrix,

wherein said pixel circuit comprises:

a display element;

a drive transistor of a first conductivity type for controlling a current flowing in said display element;

a capacitor provided at a control electrode of said drive transistor; and

a switch, connected to said control electrode of said drive transistor, for holding a drive control signal at said capacitor, and

said switch includes a switching transistor of the first conductivity type and a switching transistor of a second conductivity type in which one main electrode of said switching transistor of the first conductivity type and one main electrode of said switching transistor of the second conductivity type are connected, and one of the other main electrode of said switching transistor of the first conductivity type and the other main electrode of said switching transistor of the second conductivity type is connected to said control electrode of said drive transistor.

2. An apparatus according to claim 2, wherein

the other one of the other main electrode of said switching transistor of the first conductivity type and the other main electrode of said switching transistor of the second conductivity type is connected to one main electrode of said drive transistor, and

by turning on both of said switching transistor of the first conductivity type and said switching transistor of the second conductivity type, said control electrode and said one main electrode of said drive transistor are short-circuited.

3. An apparatus according to claim 2, wherein the other main electrode of said switching transistor of the first conductivity type is connected to said control electrode of said drive transistor.

4. An apparatus according to claim 3, wherein

a switching transistor of the second conductivity type for selecting a row is provided between said one main electrode of said drive transistor and a signal line,

a switching transistor of the first conductivity type for selecting light emission is provided on a path of the current flowing in said display element, and

a control electrode of said switching transistor of the second conductivity type, a control electrode of said switching transistor for selecting the row, and a control electrode of said switching transistor for selecting the light emission are connected in common to a second scan signal line.

5. An apparatus according to claim 2, wherein after the time when said switching transistor of the first conductivity type is changed from ON to OFF, said switching transistor of the second conductivity type is changed from ON to OFF.

6. An apparatus according to claim 2, wherein the other main electrode of said switching transistor of the second conductivity type is connected to said control electrode of said drive transistor.

7. An apparatus according to claim 6, wherein

a switching transistor of the second conductivity type for selecting a row is provided between said one main electrode of said drive transistor and a signal line,

a switching transistor of the first conductivity type for selecting light emission is provided on a path of the current flowing in said display device, and

a control electrode of said switching transistor of the second conductivity type, a control electrode of said switching transistor for selecting the row, and a control

electrode of said switching transistor for selecting the light emission are connected in common to a second scan signal line.

8. An apparatus according to claim 1, wherein

the other one of the other main electrode of said switching transistor of the first conductivity type and the other main electrode of said switching transistor of the second conductivity type is connected to an output terminal of a voltage buffer, and

an input terminal of said voltage buffer is connected to a signal line.

9. An apparatus according to claim 1, wherein

the other one of the other main electrode of said switching transistor of the first conductivity type and the other main electrode of said switching transistor of the second conductivity type is connected to an output terminal of a source-follower circuit, and

an input terminal of said source-follower circuit is connected to a signal line.

10. An apparatus according to claim 1, wherein

the other one of the other main electrode of said switching transistor of the first conductivity type and the other main electrode of said switching transistor of the second conductivity type is connected to an output terminal of a feedback type operational amplifier, and

an input terminal of said feedback type operational amplifier is connected to a signal line.

11. An apparatus according to claim 1, wherein said drive transistor of the first conductivity type and said switching transistor of the first conductivity type are p-channel type thin film transistors and said switching transistor of the second conductivity type is an n-channel type thin film transistor.

12. A driving device of a load, comprising:

a drive transistor of a first conductivity type for controlling a current flowing in said load;

a capacitor provided at a control electrode of said drive transistor; and

a switch, connected to said control electrode of said drive transistor, for holding a drive control signal at said capacitor, and

said switch includes a switching transistor of the first conductivity type and a switching transistor of a second conductivity type in which one main electrode of said switching transistor of the first conductivity type and one main electrode of said switching transistor of the second conductivity type are connected, and

one of the other main electrode of said switching transistor of the first conductivity type and the other main electrode of said switching transistor of the second conductivity type is connected to said control electrode of said drive transistor.

13. A device according to claim 12, wherein a plurality of circuits each having said drive transistor of the first conductivity type, said capacitor, and said switch are arranged in a matrix.

14. An electro-luminescent display apparatus comprising:

a plurality of pixel circuits arranged in a matrix,

an electro-luminescent display element on said pixel circuit;

wherein said pixel circuit comprises:

a drive transistor of a first conductivity type for controlling a current flowing in said display element;

a capacitor provided at a control electrode of said drive transistor; and

a switch, connected to said control electrode of said drive transistor, for holding a drive control signal at said capacitor, and

said switch includes a switching transistor of the first conductivity type and a switching transistor of a second conductivity type in which one main electrode of said switching transistor of the first conductivity type and one main electrode of said switching transistor of the second conductivity type are connected, and one of the other main electrode of said switching transistor of the first conductivity type and the other main electrode of said switching transistor of the second conductivity type is connected to said control electrode of said drive transistor.

15. A light emitting apparatus comprising:

a plurality of pixel circuits arranged in a matrix,

a light emitting element being connected with said pixel circuit;

wherein said pixel circuit comprises:

a drive transistor of a first conductivity type for controlling a current flowing in said display element;

a capacitor provided at a control electrode of said drive transistor; and

a switch, connected to said control electrode of said drive transistor, for holding a drive control signal at said capacitor, and

said switch includes a switching transistor of the first conductivity type and a switching transistor of a second conductivity type in which one main electrode of said switching transistor of the first conductivity type and one main electrode of said switching transistor of the second conductivity type are connected, and one of the other main electrode of said switching transistor of the first conductivity type and the other main electrode of said switching transistor of the second conductivity type is connected to said control electrode of said drive transistor.

* * * * *

专利名称(译)	有源矩阵型显示装置和负载的驱动装置		
公开(公告)号	US20050285151A1	公开(公告)日	2005-12-29
申请号	US11/152188	申请日	2005-06-15
[标]申请(专利权)人(译)	佳能株式会社		
申请(专利权)人(译)	佳能株式会社		
当前申请(专利权)人(译)	佳能株式会社		
[标]发明人	KAWASAKI SOMEI		
发明人	KAWASAKI, SOMEI		
IPC分类号	G09G3/32 H01L27/12 H01L29/745		
CPC分类号	G09G3/325 G09G2300/0842 H01L27/3244 H01L27/12 G09G2320/0238		
优先权	2004186483 2004-06-24 JP		
其他公开文献	US7608861		
外部链接	Espacenet USPTO		

摘要(译)

一种有源矩阵型显示装置，具有以矩阵形状排列的多个像素电路(1)。像素电路具有：显示装置(EL)；第一导电类型的驱动晶体管(M1)，用于控制在显示装置中流动的电流；电容器(C1)设置在驱动晶体管的控制电极上；开关(M2a, M2b)，连接到驱动晶体管的控制电极，用于在电容器上保持驱动控制信号。该开关包括第一导电类型的开关晶体管(M2a)和第二导电类型的开关晶体管(M2b)，其中第一导电类型的开关晶体管的一个主电极和第二导电类型的开关晶体管的一个主电极。第二导电类型串联连接。第一导电类型的开关晶体的另一个主电极和第二导电类型的开关晶体的另一个主电极连接到驱动晶体管的控制电极。

